

DOMITOR630L DOMITOR1230L

Electric Pizza Deck Oven



DOMITOR630LDG



DOMITOR1230LEM

- Single or Double chamber electric deck oven
- Digital controls (**DG**) or Electromechanical controls (**EM**)
- Easy read internal temperature display
- Maximum working temperature 400°
- Independent control for top and bottom heat
- Refractory stone baking surface
- Bake direct on the stone or in trays
- Internal halogen light
- Stainless steel front, door and handle

ACCESSORIES

- OMSU361 - Painted steel stand
- OMO7305- Neutral chamber
- OMO7311 - Heated chamber
- OME3L36RO - Set of 7 slide bars for trays
- OME3L37RO - Central element for slide bars (required with OME3L36RO)
- OMAC100RO - Set of 4 wheels, 2 with brakes

Also Available

- DOMITOR630LEM - Single Chamber - Electromechanical
- DOMITOR630LDG - Single Chamber - Digital
- DOMITOR1230LEM - Double Chamber - Electromechanical
- DOMITOR1230LDG - Double Chamber - Digital



Electromechanical



Digital

DOMITOR630L

DOMITOR1230L

Electric Pizza Deck Oven



moффat.com.au

Australia

Moffat Pty Limited

Victoria/Tasmania

740 Springvale Road
Mulgrave, Victoria 3170
Telephone 03-9518 3888
Facsimile 03-9518 3833
vsales@moffat.com.au

New South Wales

Telephone 02-8833 4111
nswsales@moffat.com.au

South Australia

Telephone 03-9518 3888
vsales@moffat.com.au

Queensland

Telephone 07-3630 8600
qldsales@moffat.com.au

Western Australia

Telephone 08-9413 2400
wasales@moffat.com.au

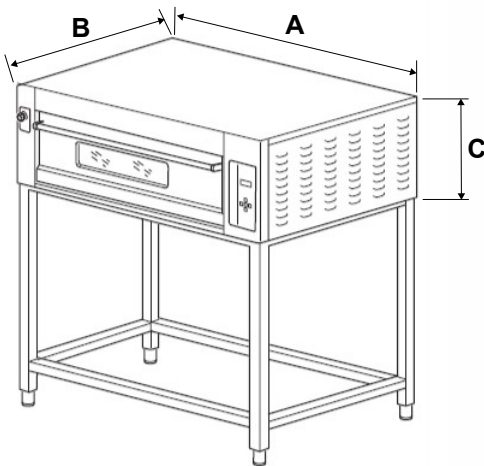

DOMITOR630L



DOMITOR1230L

SPECIFICATIONS - DOMITOR630L

External Dimensions

Width (A) 1250mm
Depth (B) 970mm
Height (C) 400mm

Electrical Requirements

400V, 3P+N+E, 7.8kW

Internal Dimensions

Width (A) 930mm
Depth (B) 630mm
Height (C) 150mm

Nett Weight

106kg

SPECIFICATIONS - DOMITOR1230L

External Dimensions

Width (A) 1250mm
Depth (B) 970mm
Height (C) 730mm

Electrical Requirements

400V, 3P+N+E, 15.6kW

Internal Dimensions

Width (A) 930mm
Depth (B) 630mm
Height (C) 150mm

Nett Weight

181kg

Important Notice:

Models and specifications are subject to change without notice. This spec sheet is meant for commercial purpose only. For technical documentation please refer to our service manuals.



© Copyright Moffat Ltd
AU.OEM.1901