

CB9-B

900mm Gas Barbecue Bench Model



CB9-B

- Countertop Bench Model
- 900mm wide
- Stainless steel grease tray
- Reversible top grates
- Inclined position to reduce flare and enhance grease run
- 3 x 33MJ/hr, 9kW aluminised burners
- Flame failure protection with continuous pilot burner and piezo ignition
- Lift out grates, radiants and baffles for cleaning
- Adjustable bench feet
- Stainless steel finish

OVERALL CONSTRUCTION

- Six 135mm wide x 550mm long reversible cast iron top grates
- Cast iron burner radiants and aluminised steel baffles
- Aluminised steel burners
- Stainless steel front, sides and splashback
- Vitreous enamelled control panel
- Stainless steel grease tray
- 63mm dia. stainless steel adjustable bench feet

CONTROLS

- Large easy use control knobs
- Dual controls with variable high to low burner setting
- Pilot, flame failure and piezo ignition to each burner

CLEANING AND SERVICING

- Lift out radiants, burners and grease tray baffles
- Lift out stainless steel top grate and radiant supports
- Easy clean stainless steel exterior
- Access to all parts from front of unit

Matching Products



CW2H



CSP6



CN4



CT9



CW3H



CW1H



CP4



CS9 / C900-S

CB9-B

900mm Gas Barbecue Bench Model

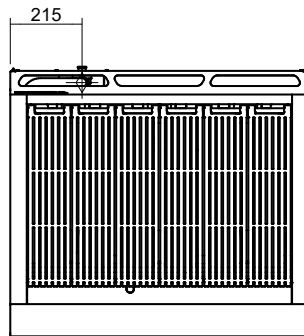
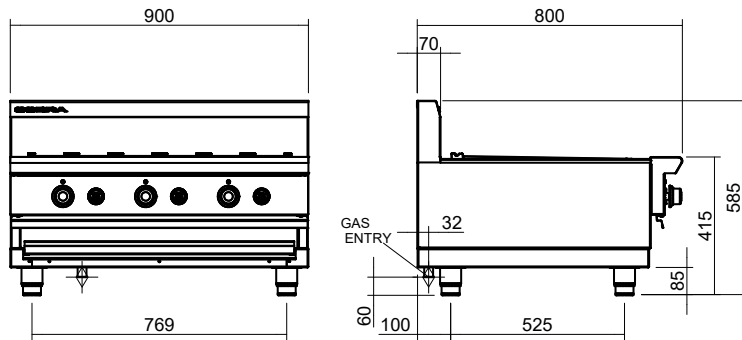

SPECIFICATIONS

Burners
3 x 33MJ/hr, 9kW U-burners

Gas power (gross)
99MJ/hr, 27kW

Cooking surface area
800mm x 540mm, 4320cm²

Gas connection
R 1/2 (BSP) male
215mm from LH side, 32mm from rear, and 60mm from bench

Dimensions
Width 900mm
Depth 800mm
Height 415mm
Incl. splashback 585mm

Nett weight
103kg

Packing data
0.72m³, 138.5kg
Width 1010mm
Depth 955mm
Height 750mm

Gas types
Available in Natural gas and LP gas,
please specify when ordering
Other gas types on request

moffat.com.au
moffat.co.nz

Australia
moffat.com.au

Moffat Pty Limited
Victoria/Tasmania
740 Springvale Road
Mulgrave, Victoria 3170
Telephone +613-9518 3888
Facsimile +613-9518 3833
vsales@moffat.com.au

New South Wales
Telephone +612-8833 4111
nswsales@moffat.com.au

South Australia
Telephone +613-9518 3888
vsales@moffat.com.au

Queensland
Telephone +617-3630 8600
qldsales@moffat.com.au

Western Australia
Telephone +618-9413 2400
wasales@moffat.com.au

New Zealand
moffat.co.nz

Moffat Limited
Rolleston
45 Illinois Drive
Izone Business Hub
Rolleston 7675
Telephone +64 3-983 6600
Facsimile +64 3-983 6660
sales@moffat.co.nz

Auckland
Telephone +64 9-574 3150
sales@moffat.co.nz



Cert. No. AGA 6878G

In line with policy to continually develop and improve its products, Moffat Limited reserves the right to change specifications and design without notice.

© Copyright Moffat Ltd
AN.C.01.19 / 1598