



Manufactured By
ROBAND AUSTRALIA PTY LTD



OPERATING INSTRUCTIONS

SALAMANDER

Models: SA15 Version 1

Includes

International models: -F

Alternative plate models: ...S, ...R, ...ST and ...RT

Special Features:

- Variable Multi-Rack Positions
- Ultra-Durable Stainless Steel Elements
- Easy Clean Crumb Tray & Reflector
- Wall Mount Kit series



These instructions cover the models of ROBAND® Salamander toasters and grillers listed above. Although there are slight variances between models, the installation, operation, care and maintenance procedure is the same for all

Roband® Australia is a wholly Australian owned company and has been manufacturing quality commercial catering equipment for the food service industry for more than 50 years. Roband products are engineered and manufactured to the highest standards to provide functionality, reliability and durability, and our quality products are exported world-wide.

Included in the comprehensive Roband® range are Toasters, Fryers, Milkshake Mixers, Rotisseries, Food Display Cabinets and much more.

Roband® Australia also acts as the Australian agents for Vitamix® Blenders, Noaw® Meat Slicers, Förje® Cookware, Robalec™ Soup/Rice Warmers, Robatherm Urns, Austheat® Fryers, Dipo Induction & Autofry Machines. Roband also has its own line of commercial cookware and cutlery under the Robinox® brand name.

For a complete set of brochures please contact your nearest authorised dealer or contact Roband directly at our head office.

Roband Head Office Sydney, Australia			
Roband Australia Pty Ltd 1 Inman Road Dee Why NSW 2099 AUSTRALIA		Tel: +61 2 9971 1788 Fax: +61 2 9971 1336 Email: sales@roband.com.au Web: www.roband.com.au	
International Agents For additional agents please email Head Office			
Cyprus:	United Catering Equipment Supplies Ph: +357 777 777 24	Switzer-land:	Burgi Infra Grill Ph: +41 418 554 552
Fiji:	Hotel Equipment Ltd Ph: +679 672 0666	Thailand:	Seven Five Distributors Co Ltd Ph: +662 866 5858
Hong Kong:	Chung Wah Kitchen Machine Ltd Ph: +852 2334 5411	United Arab Emirates:	Boncafe Middle East LLC +9714 282 8742
Malaysia:	Allied Food Equipment Ph: +603 9133 5833	United Arab Emirates:	Nisa Trading LLC +9714 396 6132
Maldives:	Radiant Heat Maldives Pty Ltd Ph: +960 333 4845	United Kingdom:	Metcalfe Catering Equipment Ph +44 1766 830 456
New Zealand:	Roband New Zealand Ph: +649 274 1354	USA:	Condon & Fisher International Ph: +1 508 361 9226
Noumea:	Comptoir Materiel Professionnel Ph: +687 28 50 43	USA:	Condon & Fisher International Ph: +1 508 361 9226
Papua New Guinea:	Brian Bell & Company Pty Ltd Ph: +675 325 5411	NETHERLANDS:	AKB Bert Muller Ph: +31 306 017 442
Singapore:	Allied Foodservice Equipment Ph: +65 62525880	GREECE:	K&N Engineers Ltd Ph: +30 210 520 0440

© Copyright 2014 – Roband® Australia Pty Ltd

All rights reserved. No part of this work may be reproduced or copied in any form or by any means, electronic or mechanical, including photocopying or posting to a website, without the written permission of the publisher. The material contained within this document is intended entirely for instructional purposes.

CONTENTS

INTRODUCTION	1
GENERAL PRECAUTIONS	1
PACKAGING	2
COMPLIANCE	2
INSTALLATION	3
OPERATION.....	4
GENERAL SAFETY	5
CLEANING, CARE & MAINTENANCE	6
TROUBLESHOOTING.....	7
SPECIFICATIONS.....	7
CIRCUIT DIAGRAM.....	8
SPARE PARTS LIST	9
APPENDIX A	10
EC DECLARATION OF CONFORMITY.....	11
WARRANTY	12

INTRODUCTION

Congratulations on your purchase of this quality ROBAND® product. With proper care and management your new purchase will give you years of trouble free service.

By reading these instructions carefully you can ensure that this machine is used and maintained properly, helping your new investment to perform well for you now, and to continue performing in the many years to come.

GENERAL PRECAUTIONS

This machine must only be operated by qualified person(s) who are fully versed in the operating and safety instructions described in this manual. Servicepersons should be instructed to familiarise themselves with any and all safety instructions described in this manual prior to commencement of any maintenance or service.

 These machines are heating units, and as with any commercial heating unit the surfaces on these Toasters will get hot. Always be careful when near an operating Toaster, and ensure that any risk to unwary customers or staff is minimised with additional signage if necessary. Due to the obvious heat hazard Roband recommends that these units be kept out of reach of children. Do not allow children to play with these units.

In the case of new personnel, training is to be provided in advance. These machines should not be operated by persons (including children) with reduced physical, sensory or mental capabilities, or lack of experience or knowledge, unless they have been given supervision or instruction concerning the safe use of the appliance by a person responsible for their safety.

These Toasters are for use with sliced bread and other bread products. The performance of this unit cannot be guaranteed for non-bread product such as Pizza, or for unusually thick or moist bread products.

 The machine should be disconnected from all power and allowed to cool before cleaning. Any damaged plug or cord should be replaced before further use.

Roband will accept no liability if;

- ◆ Non-authorized personnel have tampered with the machine.
- ◆ The instructions in this manual have not been followed correctly.
- ◆ Non-original spare parts are used.
- ◆ The machine is not cleaned correctly, with the right product.
- ◆ There is any damage to the unit.
- ◆ The machine has been modified in any way.

PACKAGING

All care is taken when packing and Roband® ensures that every unit is functional and undamaged at the time of packaging.

The Package should include:

- 1) One Salamander, Model S15
- 2) One cooking rack
- 3) Wall Mount Kit
- 4) This manual
- 5) Packaging Materials

Any damage to the machine as a result of freight must be reported to the Freight Company and to the agent responsible for the dispatch of said unit within 24 hours of receipt. No claims will be accepted or entertained after this period.



RCM:

Roband® products have been designed and manufactured to comply with any and all specifications set out by the Australian Communications and Media Authority (ACMA) in regards to Electromagnetic Compatibility. As testament to such compliance these units bear the RCM symbol.

For further information contact the Australian Communications Authority, PO Box 13112, Law Courts, Melbourne VIC 8010.

CE:

Roband® products bearing the CE compliance mark have been designed and manufactured to comply with European Standards and Directives. A copy of the CE Declaration of Conformity is located at the back of these instructions.

INSTALLATION

Remove all the packaging materials and tape, as well as any protective plastic from the machine. Clean off any glue residue left over from the protective plastic using methylated spirit.

Place the salamander on a firm, level surface in the required position. Before connecting the toaster to the power supply ensure that all the controls are in the "OFF" position.

The S15 plugs into a standard, single phase, 15Amp power point.

WALL MOUNT INSTALLATION

Remove Plastic film from Wall Bracket Parts. Install Stand Off Plate onto SA15 machine by lining up holes with back face of lower control box and fix in place using 2 self-tapper screws (provided).

Position wall bracket hooks on wall in desired location and so that mounting centres are 565mm apart. Fix in place using appropriate fasteners for the material being mounted to.

NOTE: Ensure installation is of sufficient quality and workmanship to support the load of the appliance. WHEN WALL MOUNTED THE SA15 HAS A MAXIMUM LOAD CAPACITY OF 20KG. NO ITEMS SHOULD BE PLACED ON TOP OF A WALL MOUNTED SA15

Angle SA15 at 45° so that the top tilts backwards and place SA15 onto the Wall Mount Hooks so that the cut-out on the rear of the SA15 back panel mates up with the hook profile. Carefully tilt forward till stand-off plate rests on the wall.

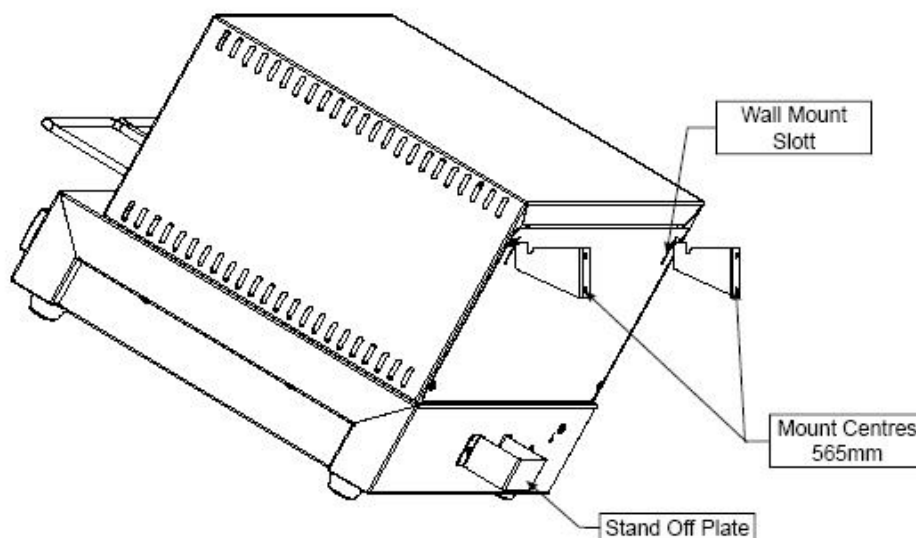

OPERATION

Turn ON the unit by rotating either of the knobs to any position other than OFF.

The cooking area of the salamander is divided into left and right halves. An energy regulator individually controls the element on each side. Select the desired heat setting on either or both energy regulators.

The pilot light(s) will illuminate indicating that heating is taking place.

In quiet times it may be preferable to leave the energy regulators on a setting of “2” as this will keep some heat in the elements and shorten the “recovery time” when demand picks up.

⚡ SAFETY ⚡

GENERAL SAFETY

This machine contains no user-serviceable parts. Roband® Australia, one of our agents, or a similarly qualified person(s) should carry out any and all repairs. Any repair person(s) should be instructed to read the Safety warnings within this manual before commencing work on these units.



Steel cutting processes such as those used in the construction of this machine result in sharp edges. Whilst any such edges are removed to the best of our ability it is always wise to take care when contacting any edge. Particular care should be taken when panels are removed (eg during servicing) as this may expose sharp edges.

Do not remove any cover panels that may be on the machine.

This unit can get **very** hot, ensure everyone is aware that the machine is operating and take care to avoid contact with hot surfaces. Hot surfaces should be left well ventilated with an air gap of at least 100mm, though common sense should be used if the machine is near heat-sensitive materials.

National Standards exist outlining the positioning, spacing and ventilation requirements when installing new appliances. These Standards should be consulted and new equipment should be installed accordingly. In any situation where specifications allow a distance of less than 100mm we would still recommend that a well-ventilated air gap of not less than 100mm be maintained on all sides. If the machine is near particularly heat-sensitive materials common sense should be employed in determining sufficient distancing.



Always ensure the power cable is not in contact with hot parts of the machine when in use. Ensure that any damaged power cord is replaced before further use.

DO NOT place any additional load on SA15 when wall mounted as this may exceed the wall mounts maximum load capacity. Maximum load is 25Kg.

CLEANING, CARE & MAINTENANCE

Attention to regular care and maintenance will ensure long and trouble free operation of your Salamander.

- ◆ Ensure the power is off and the salamander is cool before attempting to clean any part of the machine.
- ◆ Wipe the salamander down with warm soapy water using a **damp** sponge or cloth. **Do not** immerse the salamander in water or allow the ingress of water into the ventilation holes or controls.
- ◆ Daily cleaning of the crumb/drip tray is essential. The crumb/drip tray may be removed by sliding it out from the salamander. The crumb/drip tray should be emptied and washed with warm soapy water.
- ◆ The top reflector should also be checked and cleaned periodically. The reflector is located on the underside of the top. To remove the reflector, simply slide it out.
- ◆ Always ensure the power cable is not in contact with hot parts of the salamander when in use, and have any damaged power cord replaced immediately.

Note: The reflective surfaces of the crumb/drip tray and top reflector aid the cooking process. Over time, these surfaces may become tarnished and this reduces the efficiency and performance of the salamander. To overcome this, aluminium foil can be wrapped over these two components to restore a good reflective surface. This foil can then be replaced when necessary.

CAUTION: Although every care is taken during manufacture to remove all sharp edges, care should be taken when cleaning and handling the salamander to avoid injury.

CAUTION: Some cleaning agents can damage stainless steel, usually through prolonged use. For this reason we recommend cleaning with soapy water. Any damage to the unit through the use of harsh or improper cleaning agents is entirely the fault of the user.



Warning: this unit must never be cleaned with the use of a water jet, as any such use is dangerous and will void the warranty.

TROUBLESHOOTING

If the grill does not heat up check the following points before calling for service.

- ✓ The salamander is plugged in correctly and the power switched on.
- ✓ The power point is not faulty.
- ✓ The energy regulator(s) are not in the "OFF" position.
- ✓ Check that the safety switch (RCD) hasn't been tripped. Read Appendix A on page 10 of this manual on RCD'S (residual current devices) for a full explanation.

Only after all these points have been checked should you call for service.

SPECIFICATIONS

Model	SA15
Power Source (Volts AC)	230
Power Consumption (Watts)	3200
Nominal Dimensions	
Width (mm)	690
Height (mm)	355
Depth (mm)	455 (Machine Only)

Constant research and development may necessitate specification changes at any time.

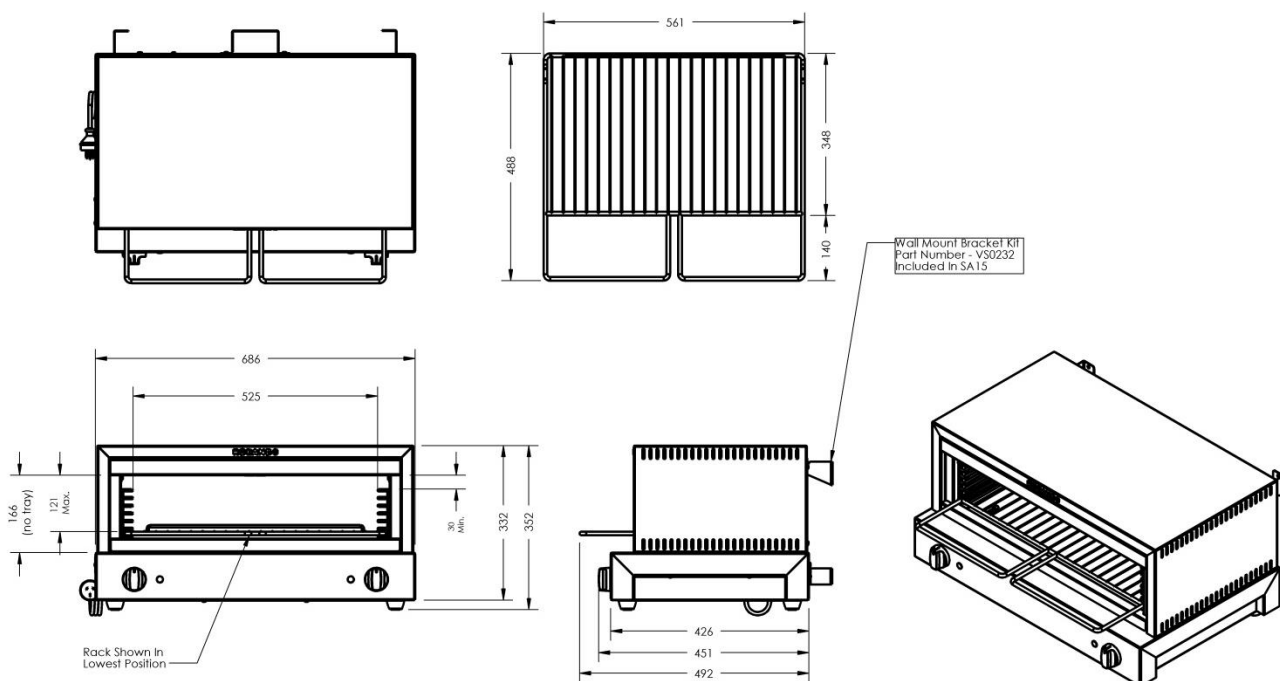

CIRCUIT DIAGRAM

All Models

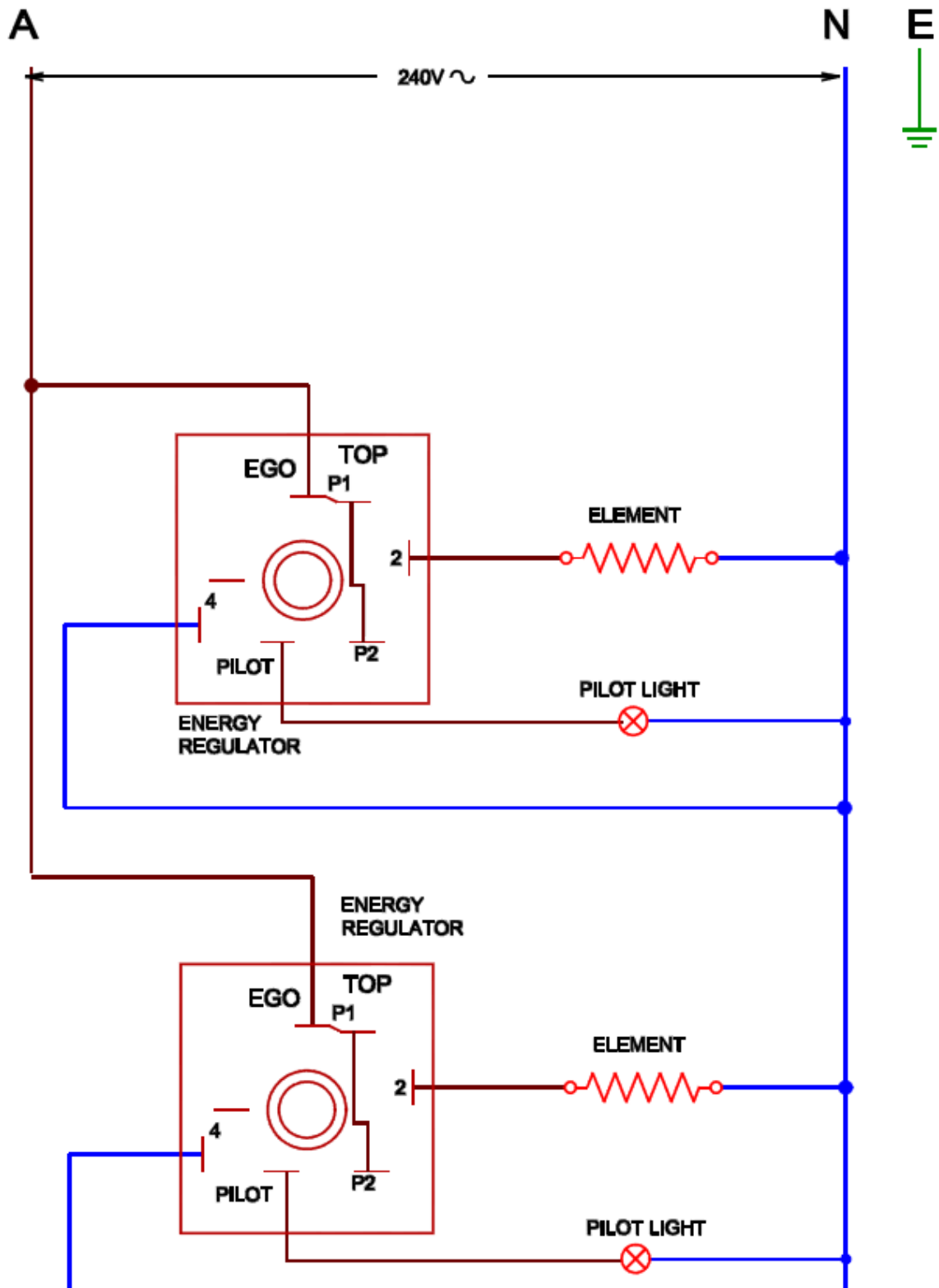

Note: This circuit diagram has been provided for reference and to assist qualified service and repair agents only. Under no circumstances should persons not suitably qualified attempt repairs to any electrical equipment.

SPARE PARTS LIST

Part No:	Description:	Qty:
EC0031	Terminal Block - Porcelain/Steatite "1602", L & N marked, 10mm sq.	1
EC0306	Plug & Cord - 15 Amp Black Thermoset Elastomer - 2BL 1E	1
EC0395	Pilot Light - Amber, 10mm Screwed (includes Nut)	2
ES0264	Pilot Light and Viton O-ring - Amber, 10mm screwed (includes nut)	2
HC0152	Element - 1600W 230V	2
MC0846	Knob & Spring - Roband® Satin Finish - 6mm 0°	2
MC0888	Rack	1
MC0896	Element Support Bar - 5/16 303 stainless	1
PC0061	Cord Clamp - 15A	1
PC0072	Bush - Ø5/8" Nylon 6/6	2
PS0129	Foot & Foot Cap Set (includes M6x16 Screws)	1
SS2615	Crumb Tray - SA15	1
SS2616	Reflector - SA15	1
TC0001	Energy Regulator (includes nut)	2
TS0021	Energy Regulator and Aluminium Knob	2
VS0232	Wall Mount Kit - SA15	1
VS0260	Side Rack Assembly - Zigzag Screw In Type	2

APPENDIX A

RESIDUAL CURRENT DEVICES (RCD'S)

Also known as Earth Leakage Protection systems an RCD is a protective device that automatically disconnects the live conductors of a circuit when an earth leakage current reaches a predetermined value.

Australian and International Standards detail when and where RCD's are to be used in electrical installations, but common practice in many countries is to use a 30mA RCD in general commercial applications. This is typically done because 30mA RCD's are readily available and are used in domestic installations.

For Commercial installations, and for socket-outlets providing power to commercial heating equipment (Toasters, Bains Marie, Grillers), 30mA RCD's are typically unsuitable unless they are protecting only one device. Higher rated RCD's should be considered if protecting multiple socket-outlets, giving appropriate consideration to the type of equipment being protected.

AS/NZS3000 2.5.2 gives the following warnings that should have been taken into consideration when an RCD circuit was installed.

To avoid unwanted tripping due to leakage currents and transient disturbances, care should be taken to ensure that the sum of the leakage currents of electrical equipment on the load side of an RCD is less than 1/3 of its rated residual current.

To avoid excessive leakage current causing unwanted tripping where socket-outlets are protected by one RCD having a rated residual current not greater than 30mA, consideration should be given to the number of socket-outlets protected and the nature of electrical equipment likely to be connected to the socket-outlets.

Tubular elements (such as those used in this unit) reaching temperatures greater than 110°C are subject to moisture absorption and therefore earth leakage current generation. Should the installation and use of this unit trip an RCD the unit will need to be run on a circuit without an RCD for approximately 30-60 minutes, after which time the elements should have dried out and the machine should function normally. If you are unable to locate a circuit without an RCD please contact your supplier or contact Roband® or our Agent for alternative suggestions.

EC DECLARATION OF CONFORMITY

Manufacturer	Roband® Australia 1 Inman Rd Cromer NSW, 2099 Australia
Model Type	Salamander
Description	Open Front Toaster
Date of first CE Marking	1st Sep 2010
Specific Models	SA15 Includes export model: -UK, -F

STANDARDS:

This machine is designed in compliance with

- Machinery Directive 2006/42/EC
- Low Voltage Directive 2006/95/EC
- EMC Directive 89/336/EEC including amendments to 93/68/EEC
- WEEE Directive 2002/96/EC (WEEE)
- Restriction of Hazardous Substances in Electrical and Electronic Equipment 2002/95/EC (RoHS)
- EN60335.1 Household and similar Electrical Appliances
- EN60335-2-48 Commercial Electric Toasters and Grillers
- EN55014.2: 1997 Electromagnetic compatibility. Requirements for household appliances, electric tools and similar apparatus. Immunity.

ENVIRONMENTAL:

This product is designed in order to contribute as little as possible to the quantity and noxious nature of waste and risk of pollution or other environmental contamination.

Packaging materials used in this machine are designed to be recyclable.

DECLARATION

I hereby declare under our sole responsibility that the product mentioned above to which this declaration relates complies with the above-mentioned standard(s).

Roband® Australia has appointed Valera Ltd as our EU Authorised Representative of :

5-7 The Glade Business Centre, Eastern Ave, West Thurrock, Essex, RM203FH , UK.
Tel: 08 45 270 4321 Fax: 0845 270 4323 E-Mail : info@valera.co.uk

Signature of Authorised Person:  Date: 1st Sep 2010

Print Name: Mal Johnston Position: Director of Engineering

WARRANTY

Every care is taken to ensure that no defective equipment leaves our factory and all goods manufactured by us are guaranteed against defective workmanship and materials for a period of 12 months from the date of purchase. Roband Australia's obligations pursuant to this express warranty being limited to the repair or replacement of the defective goods or materials, at its option and subject to the terms contained within this Warranty statement. Where relevant, glass, Teflon® and lamps are **not** included in this warranty and RCD tripping due to moisture absorption by Tubular Heating Elements is not considered a warranty fault.

Generally, all goods claimed under this warranty must be returned to the factory or an authorized service agent, freight prepaid, for inspection. All parts deemed to be defective will be replaced, however, no claims will be entertained for second hand products, or parts damaged in transport, misused or modified in any way without our approval. For machines that are not considered to be portable (e.g. food bars, rotisseries, large hotplates and some bain maries), on site warranty service will be provided in capital city metropolitan areas only. In all other locations, the customer is responsible for all travelling time/service call costs and payment for this will be required prior to the commencement of the repair. The labour costs to actually repair the fault will be met by the company.

Any repairs or replacement of defective goods or materials pursuant to this warranty, must be authorized by Roband Australia prior to any action being taken. The company reserves the right to reject a claim for warranty if it is not completely satisfied with the circumstances under which it occurred and any other costs incurred for false claims or faults due to incorrect usage etc. are the responsibility of the claimant. Roband Australia Pty Ltd nor any subsidiary company or Agent shall be liable for loss of profit or damage to other equipment and property except where it is in breach of the guarantees provided in accordance with Schedule 2 of the Competition and Consumer Act 2010 (Cth) or the applicable legislation from time to time.

The goods come with guarantees that cannot be excluded under the Australian Consumer Law (ACL). You are entitled to a replacement or refund for a major failure and for compensation for any other reasonably foreseeable loss or damage. You are also entitled to have the goods repaired or replaced if they fail to be of acceptable quality and the failure does not constitute a major failure.

Generally, authorized service agents are located in all areas which have authorized distribution dealers. For the name of your nearest Australian authorised service agent, please contact:

Roband Australia Pty Ltd

1 Inman Road, Cromer, NSW 2099

Warranty Number: 1800 268 848

Phone: (02) 9971 1788 Fax: (02) 9971 1336

All other countries please contact your selling Agent.

Please complete the following details and keep this card in a safe place.

NAME _____

ADDRESS _____

MODEL No: _____ SERIAL No: _____ DATE PURCHASE _____

NAME OF DEALER: _____

PLEASE RETAIN THIS SECTION FOR YOUR RECORDS

DO NOT POST

ROBAND® AUSTRALIA PTY LTD

OTHER LEADING PRODUCTS AVAILABLE:

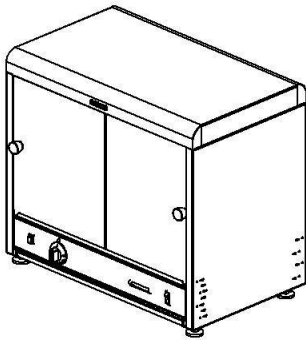

π-PLUS
PIE & FOOD WARMERS



DRINK MIXERS

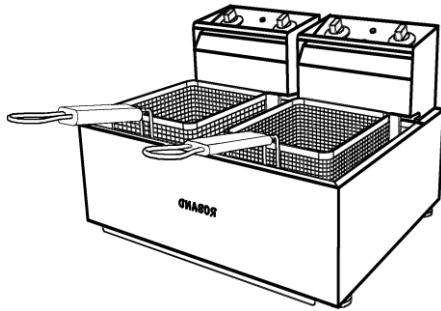

HIGH PERFORMANCE DEEP FRYERS

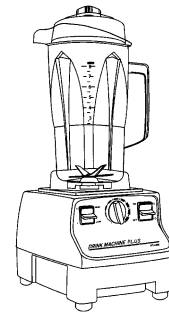

VITAMIX BLENDERS

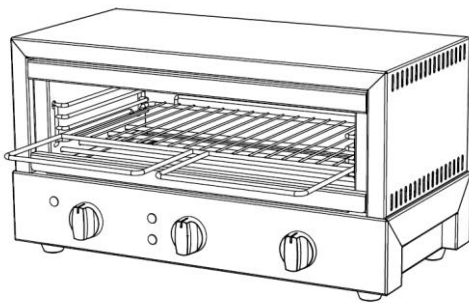

GRILLMAX TOASTERS

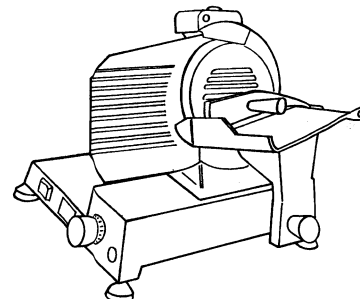

NOAW Slicers

Manufactured/Imported in Australia by:

ROBAND[®]
AUSTRALIA PTY LTD

Authorised Distributor/Agent