

ROBAND®

MANUFACTURED BY:

ROBAND®
AUSTRALIA PTY LTD

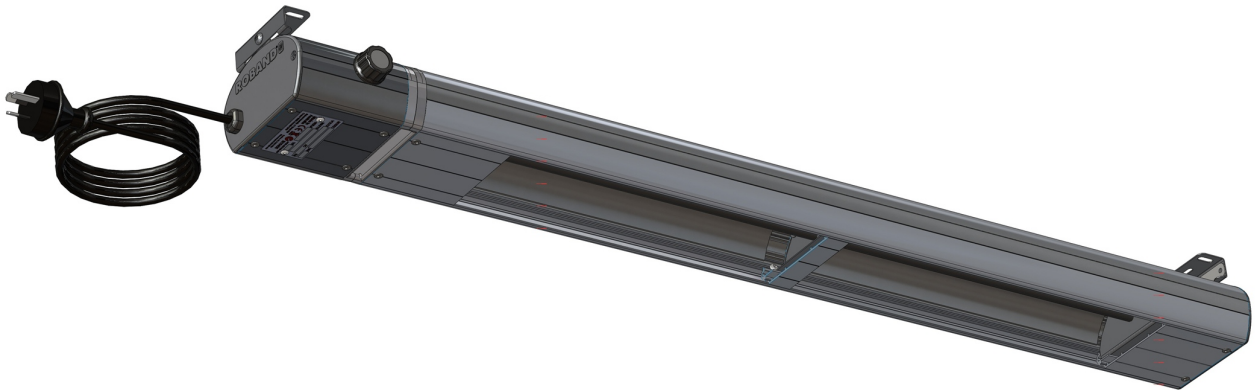

OPERATING INSTRUCTIONS INFRA-RED HEATING ASSEMBLIES

Models: HE900, HE1200, HE1500, HE1800

Version 1

includes

- Left & Right models: ...L and ...R
- International models: ...-UK and ...-F
- Alternative mounting models: ...+S and ...+R
- Fabricator models: HUE...

Special Features:

- Variable Heat Control
- Stylised Design
- Long-Life Metallic Elements

CE

These instructions cover the models of ROBAND® Heatlamps listed above. Although there are slight variances between models, the installation, operation, care and maintenance procedure is the same for all.



Roband Australia is a wholly Australian owned company and has been manufacturing quality commercial catering equipment for the food service industry for more than 50 years. Roband products are engineered and manufactured to the highest standards to provide functionality, reliability and durability, and our quality products are exported world-wide.

Included in the comprehensive ROBAND® range are Toasters, Fryers, Milkshake Mixers, Rotisseries, Food Display Cabinets and much more.

Roband® Australia also acts as the Australian agents for Vita-mix® Blenders, Noaw® Meat Slicers, Ryno® Stainless Benching, Ceado Juicers, Förje® Cookware, Robalec™ Soup/Rice Warmers, Robatherm Urns, Austheat® Fryers, Dipo Induction & Autofry Machines. Roband also has its own line of commercial cookware and cutlery under the Robinox® brand name.

For a complete set of brochures please contact your nearest authorised dealer or contact Roband directly at our head office.

Roband Head Office Sydney Australia	International Agents For additional agents please email Head Office
Roband Australia Pty Ltd 1 Inman Road DEE WHY NSW 2099 Australia Tel: +61 2 9971 1788 Fax: +61 2 9971 1336 Email: sales@roband.com.au Web: www.roband.com.au	Cyprus: United Catering Equipment Supplies Ph +357 777 777 24 Fiji: Hotel Equipment Ltd Ph +679 672 0666 Hong Kong: Chung Wah Kitchen Machine Ltd Ph +852 2334 5411 Italy: World Group Ph +39 0322 83 67 24 New Zealand Roband New Zealand Ph +649 274 1354 Papua New Guinea: Brian Bell & Company Pty Ltd Ph +675 325 5411 Singapore: Jelco Private Ltd Ph +65 5611 988 Switzerland: Burgi Infra Grill Ph +41 418 554 552 Thailand: Seven Five Distributors Co Ltd Ph +662 866 5858 United Arab Emirates: Technical Supplies and Services Co Ph +971 4343 1100 United Kingdom: Metcalfe Catering Equipment Ph +44 1766 830 456

© Copyright 2013 – Roband Australia Pty Ltd

All rights reserved. No part of this work may be reproduced or copied in any form or by any means, electronic or mechanical, including photocopying or posting to a website, without the written permission of the publisher. The material contained within this document is intended entirely for instructional purposes.

CONTENTS

INTRODUCTION	4
GENERAL PRECAUTIONS	4
PACKAGING.....	5
COMPLIANCE	5
HUE SERIES FABRICATOR MODELS	6
INSTALLATION	7
MOUNTING PROCEDURE – STANDARD MOUNTS	7
SQUARE AND ROUND MOUNTS (...+S & ...+R)	9
ELECTRICAL CONNECTION	10
OPERATION	10
GENERAL SAFETY	11
CLEANING, CARE & MAINTENANCE	12
ELEMENT REPLACEMENT	13
TROUBLESHOOTING	13
SPECIFICATIONS	14
HE SERIES CIRCUIT DIAGRAM	15
HUE SERIES CIRCUIT DIAGRAM	16
EXPLODED DIAGRAM.....	17
EC DECLARATION OF CONFORMITY	18
WARRANTY.....	19

INTRODUCTION

Congratulations on your purchase of this quality ROBAND® product. With proper care and management your new purchase will give you years of trouble free service.

By reading these instructions carefully you can ensure that this machine is used and maintained properly, helping your new investment to perform well for you now, and to continue performing in the many years to come.

GENERAL PRECAUTIONS

This machine must only be operated by qualified person(s) who are fully versed in the operating and safety instructions described in this manual. Servicepersons should be instructed to familiarise themselves with any and all safety instructions described in this manual prior to commencement of any maintenance or service.

In the case of new personnel, training is to be provided in advance. These machines should not be operated by persons (including children) with reduced physical, sensory or mental capabilities, or lack of experience or knowledge, unless they have been given supervision or instruction concerning the safe use of the appliance by a person responsible for their safety.

These machines are heating units, and as with any commercial heating unit the surfaces on these Heating Assemblies will get **very hot**. Always be careful when near an operating Heating Assembly, and ensure that any risk to unwary customers or staff is minimised with additional signage if necessary. Due to the obvious heat hazard Roband recommends that these units be kept out of reach of children.



The performance of this unit cannot be guaranteed for operational use outside its design parameters. These Heating Assemblies are designed mainly for the heating and warming of food. They are **not** designed for the cooking of food.



The machine should be disconnected from all power and allowed to cool before cleaning.

Roband will accept no liability if;

- ◆ Non-authorized personnel have tampered with the machine.
- ◆ The instructions in this manual have not been followed correctly.
- ◆ Non-original spare parts are used.
- ◆ The machine is not cleaned correctly, with the right product.
- ◆ There is any damage to the unit.

PACKAGING

Roband ensures that every unit is functional and undamaged at the time of packaging, and all care is taken.

The Package of this Heating Assembly should include:

- 1) One Heating Assembly (appropriate model)
- 2) This Manual
- 3) Packaging Materials

Any damage to the machine as a result of freight must be reported to the Freight Company and to the agent responsible for the dispatch of said unit within 24 hours of receipt. No claims will be accepted or entertained after this period.



COMPLIANCE

C-Tick:

Roband® products have been designed and manufactured to comply with any and all specifications set out by the Australian Communications Authority (ACA) in regards to Electromagnetic Compatibility. As testament to such compliance these units bear the C-Tick symbol.

For further information contact the Australian Communications Authority, PO Box 13112, Law Courts, Melbourne VIC 8010.

CE:

Roband® products bearing the CE compliance mark have been designed and manufactured to comply with European Standards and Directives. A copy of the CE Declaration of Conformity is located at the back of these instructions.

HUE SERIES FABRICATOR MODELS

If your unit is a standard HE model, please ignore the details in this section and proceed to the next section.

HUE units are provided without switches, energy regulators or control boxes. They are designed to be wired into a fabricated food bar, with remote control, and hence do not come with plugs or cord. The 500mm long Active, Neutral and Earth wiring which extends outside the Heating Assembly should be connected by a trained technician or electrician.

Please note that the energy regulator, knob and label are available for separate purchase if required.

All HUE units are suited to 220-240V AC 50-60Hz Power supply.

After the Heating Assembly has been installed, the unit is operable through whichever means has been organised by the person(s) installing the Lamp Assembly. Control may involve a remote switch or suitable energy regulator (i.e. wired separately by the fabricator some distance away from the Lamp Assembly).

These units will get very hot during operation. For this reason it is recommended that all care be taken to avoid operation in areas where contact is likely to occur. All surfaces on these units will be hot when in use.

As these Heating Assemblies are intended for use by equipment manufacturers and their application and installation are beyond Roband control, they are only covered by a limited warranty against faulty workmanship and materials for a period of 12 months from date of purchase. All goods that are claimed under this warranty must be returned to the factory, freight prepaid, for inspection. Any part deemed to be defective will be replaced, however, no claims will be entertained for parts damaged in transport, misused or modified in any way without our approval.

For HUE series Heating Assemblies please continue to read this manual in full, ignoring any reference to the control box, energy regulator, cord and plug that is present on other models.

INSTALLATION

Remove all the packaging materials and tape, as well as any protective plastic from the machine. Clean off any glue residue left over from the protective plastic or tape using methylated spirit.

These Heating Assemblies are designed for mounting above food serving and preparation areas to provide HEAT **without illumination**.

We recommend mounting heights between 320mm and 450mm above the surfaces / products to be heated. Note the lower the mounting height the smaller the heated area will be and the higher the temperature. The higher the mounting height, the larger the heated area but the lower the temperature.

Warning



These units must not be installed near flammable materials or near surfaces that could be adversely affected by high temperatures. The area immediately above the Heating Assembly will become very hot when in operation.

MOUNTING PROCEDURE – STANDARD MOUNTS

STEP 1, hold the Heatlamp in the position where it is to be mounted and mark the position of the mounting plates as shown.

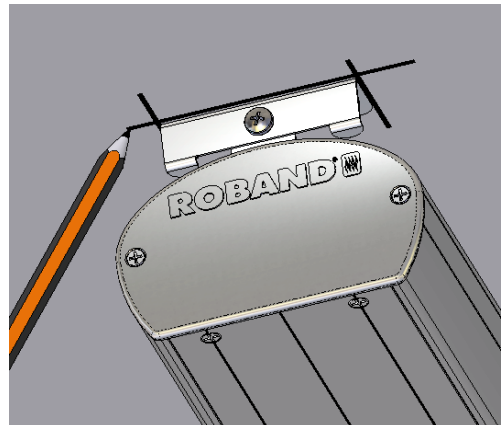

STEP 2, remove the mounting plates from the Heatlamp and position within the markings previously made and mark the drilling position for the holes through the slots in the plate as shown.

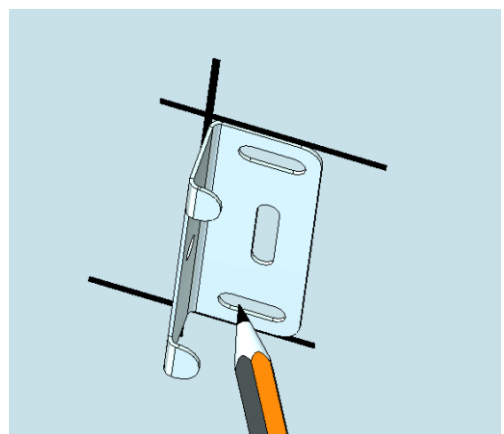

STEP 3. Drill holes on of the correct size for the mounting screws / bolts being used.

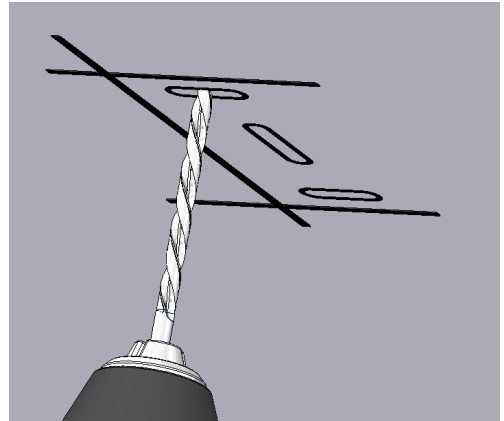

STEP 4. screw / bolt the mounting plates to the mounting face as shown.

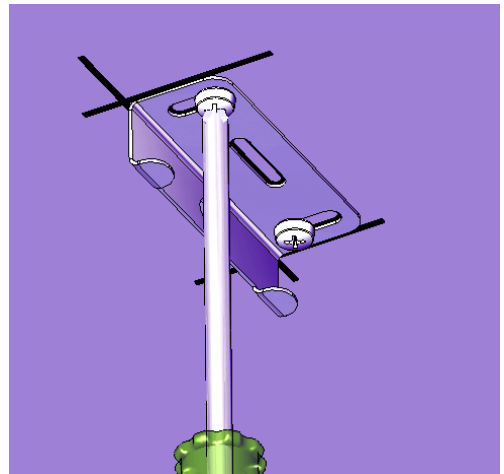

STEP 5. fit the Heatlamp hanging brackets into the mounting plates both ends at once as shown.

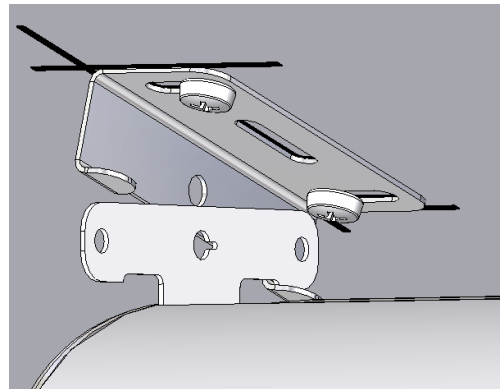

STEP 6, slide the Heatlamp into the mounting plates and lift it up at the same time then pull the Heatlamp back so that it rests on the hanging brackets as shown.

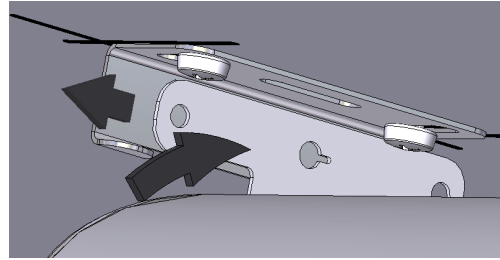

STEP 7, refit the screw locking the mounting plates to the Heatlamp hanging bracket. Do not excessively over tighten the locking screw.

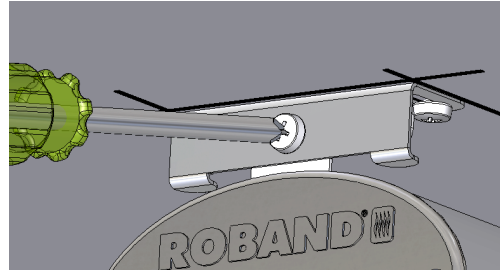

SQUARE AND ROUND MOUNTS (...+S & ...+R)

For additional mounting flexibility these models are supplied with either the round or square (pictured) mount.

**The Square Mount will accept a 3/4" (19mm) OA Square Tube (not supplied).
The Round Mount will accept a 3/4" (19mm) OA Round Tube (not supplied).**

Use screws to attach your desired tube (not included) in place, the tube needs to have adjoining screw holes drilled in it to allow the tube to be secured correctly to the heat lamp.

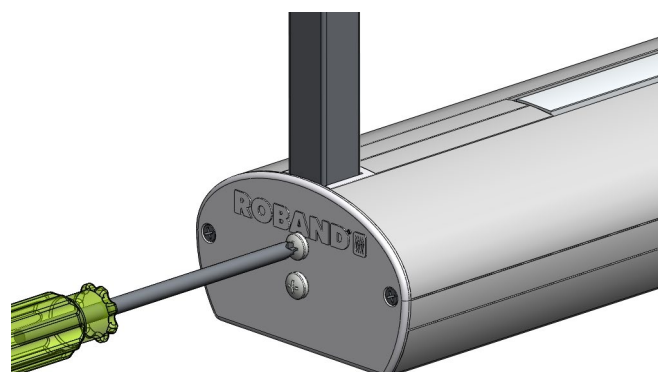
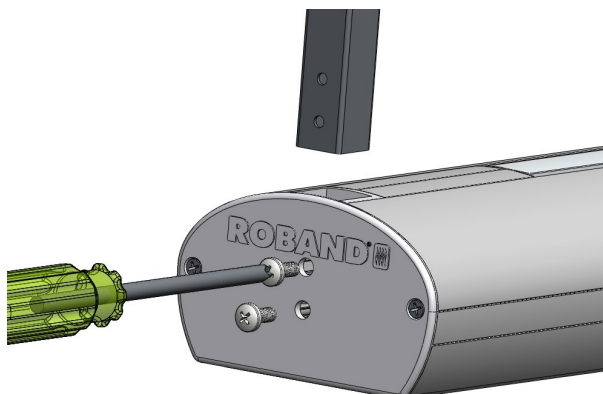

ELECTRICAL CONNECTION



Make certain that any excess cord length is kept away from the Heating Assembly body and out of the heated area.

AUSTRALIAN Models (HE...)

All Models come with a 1.8m power cord and will plug into a single phase, 10 Amp power point.

EXPORT Models (HE...-UK and -F)

Both models come with 1.8m cord. -UK Models will plug into a standard 13 Amp United Kingdom (Type G) powerpoint. -F Models will plug into a standard 16 Amp European (Type E or F) powerpoint .

Fabricator Models (HUE..)

For HUE Series a qualified electrician must connect the lamps to the electrical supply. When installing, the lamp must be wired through a suitable controlling switch placed in a position where it can be easily be operated or controlled by the person/s using the lamp. See HUE section earlier in this manual.

OPERATION

After the heat lamps have been installed, the unit is operable and temperature controlled through the use of the energy regulator which is mounted on the outside of the switch box (HE series only).

The Energy regulator is used to control the temperature output of the heating assembly from approximately 10% of the total power on low setting to 100% of the power on maximum setting.



These units will get very hot during operation. For this reason it is recommended that all care be taken to avoid operation in areas where contact is likely to occur. All surfaces on these units will be hot when in use.

As these Heating Assemblies are intended for use by equipment manufacturers and their application and installation are beyond our control, they are only covered by a limited warranty against faulty workmanship and materials for a period of 12 months from date of purchase. The tungsten halogen lamps are not included in this warranty. All goods that are claimed under this warranty must be returned to the factory, freight prepaid, for inspection. Any part deemed to be defective will be replaced, however, no claims will be entertained for parts damaged in transport, misused or modified in any way without our approval.

SAFETY

GENERAL SAFETY

This machine contains no user-serviceable parts. Roband Australia, one of our agents, or a similarly qualified person(s) should carry out any and all repairs. Any repair person(s) should be instructed to read the Safety warnings within this manual before commencing work on these units.

Steel cutting processes such as those used in the construction of this machine result in sharp edges. Whilst any such edges are removed to the best of our ability it is always wise to take care when contacting any edge.

Particular care should be taken to avoid contact with any steel edge, and warnings should be given in regards to the danger of such contact to any repair or maintenance person(s) prior to commencement of any servicing.

Do not remove any cover panels that may be on the machine.

National Standards exist outlining the positioning, spacing and ventilation requirements when installing new appliances. These Standards should be consulted and new equipment should be installed accordingly. In any situation where specifications allow a distance of less than 100mm we would still recommend that a well-ventilated air gap of not less than 100mm be maintained on all sides and that any materials closer than 100mm be non-flammable. If the machine is near particularly heat-sensitive materials common sense should be employed in determining sufficient distancing.

Ensure that any damaged cables are replaced before further use.

Keep out of reach of children or the inept.

This unit can get **very** hot. Ensure everyone is aware that the machine is operating and take care to avoid contact with hot surfaces.



Always ensure the power cable is not in contact with hot parts of the machine when in use.

Electricity is dangerous, and should only be handled by qualified professionals. It's your life – Don't risk it.

CLEANING, CARE & MAINTENANCE

Attention to regular care and maintenance will ensure long and trouble free operation of your Heating Assembly. Although scheduled servicing is not required we do recommend you adopt a program of regular maintenance to ensure that the Heating Assembly is clean and functional and to avoid inadvertently damaging the unit.

Daily cleaning should be considered mandatory for all cooking equipment. In order to ensure the proper cleaning and to avoid damage to the Heatlamp assemblies the instructions below should be followed.

- ◆ Ensure the power is off and the Heating Assembly is cool before attempting to clean any part of the machine.
- ◆ Wipe the lamp cover down with warm soapy water using a **damp** sponge or cloth. **Do not** immerse the Heating Assembly in water.
- ◆ **Do not** let any moisture enter inside the Heating Assembly or near the metallic elements
- ◆ Always ensure the power cable is not in contact with hot parts of the Heating Assembly when in use.
- ◆ Do not clean this unit with the use of a water jet.

Although every care is taken during manufacture to remove all sharp edges, care should be taken when cleaning and handling the Heating Assembly to avoid injury.

ELEMENT REPLACEMENT

In the rare case of the element failing, it should be replaced by a qualified person such as an electrician.

To access the element:

1. Turn the unit off and unplug the machine.
2. Remove the four screws from the base section underneath the element using a T20 Torx screwdriver.
3. Working from one end, squeeze the sides of the Heating Assembly together. The base section can then be pulled down with the other hand and taken off. Or insert a small flat blade screw driver into the slot provided and lever the base section off. **IMPORANT:** Ensure the base section is supported properly during removal, to ensure it does not fall down unexpectedly. Tying a string around the heat lamp at each end prior to removal will minimise the chance of losing control of the base section, particular for longer Heating Assemblies

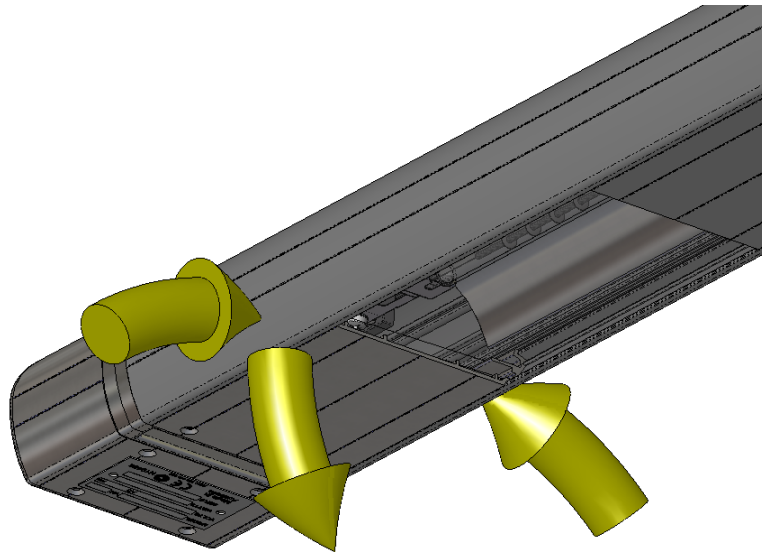

4. Replace element.
5. Snap the cover back in place and refit the four screws.
6. Tag and Test before returning to service.

TROUBLESHOOTING

If the Heating Assembly does not function check the following points before calling for service.

- ✓ The device is plugged in correctly and the power switched on.
- ✓ The power point is not faulty.

SPECIFICATIONS

Model	Power Source	Power Rating	Length - mm	Nominal Dimensions	
				Depth - mm	Height - mm
HE900	240Volts AC	900 Watts	900	108	65
HE1200	240Volts AC	1200 Watts	1200	108	65
HE1500	240Volts AC	1500 Watts	1500	108	65
HE1800	240Volts AC	1800 Watts	1800	108	65

Model	Power Source	Power Rating	Length - mm	Nominal Dimensions	
				Depth - mm	Height - mm
HUE825	240Volts AC	900 Watts	825	108	65
HUE1125	240Volts AC	1200 Watts	1125	108	65
HUE1425	240Volts AC	1500 Watts	1425	108	65
HUE1725	240Volts AC	1800 Watts	1725	108	65

Constant Research & Development may necessitate machine changes at any time.

HE SERIES CIRCUIT DIAGRAM

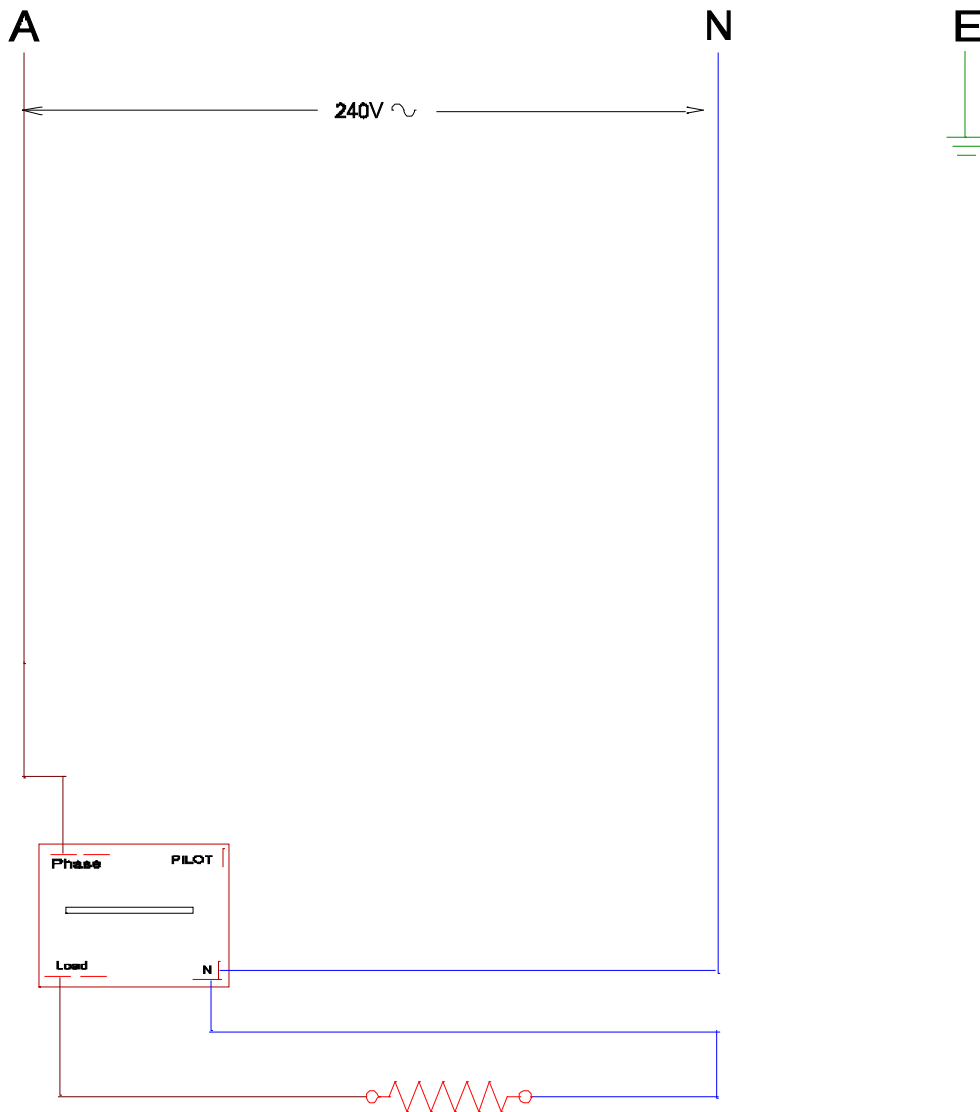

Note: This circuit diagram has been provided for reference and to assist qualified service and repair agents only. Under no circumstances should person's not suitably qualified attempt repairs to any electrical equipment.

HUE SERIES CIRCUIT DIAGRAM

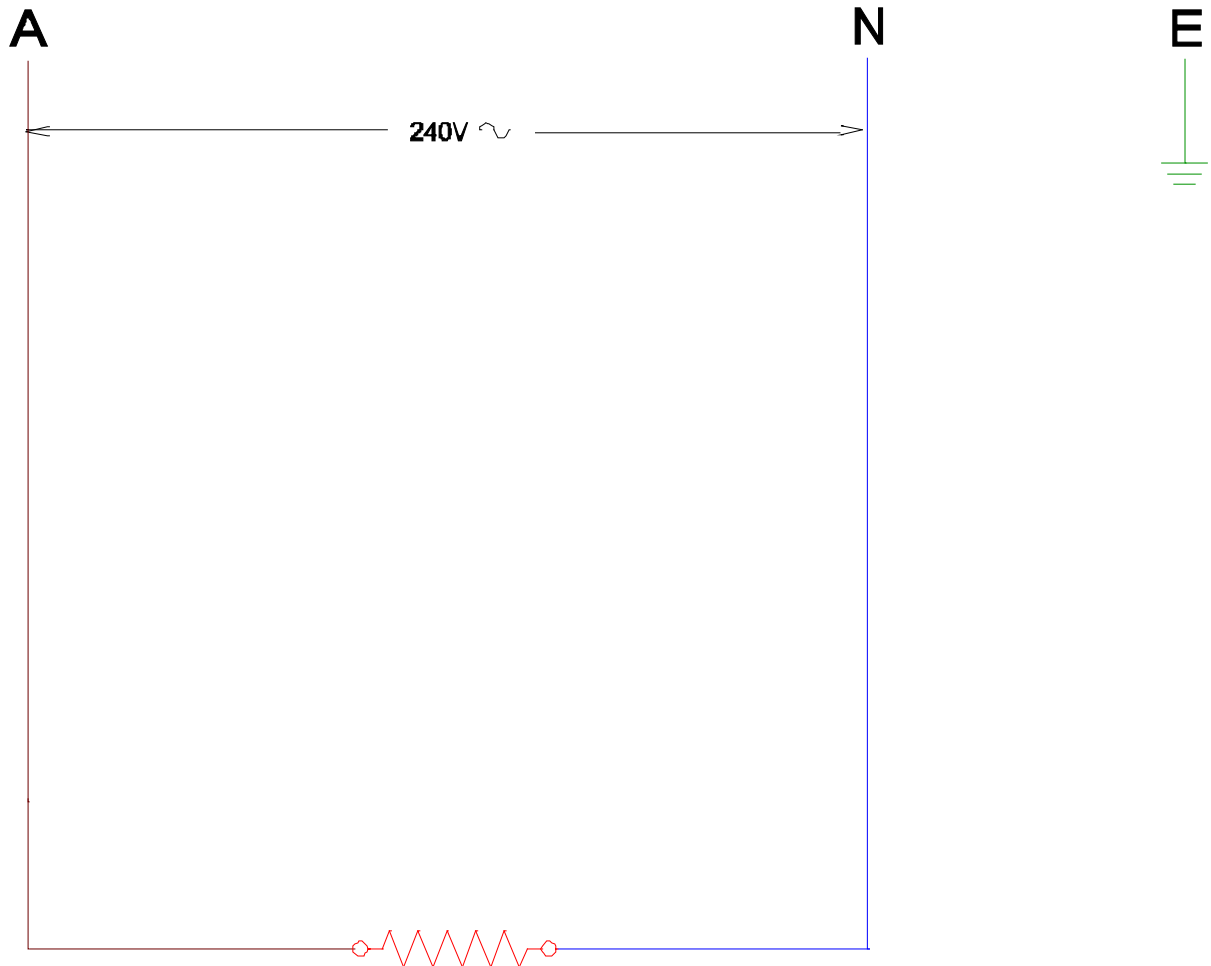

Note: This circuit diagram has been provided for reference and to assist qualified service and repair agents only. Under no circumstances should person's not suitably qualified attempt repairs to any electrical equipment.

EXPLODED DIAGRAM

(HE900 shown)

ITEM NO.	PART NUMBER	DESCRIPTION	Length	QTY.	ITEM NO.	PART NUMBER	DESCRIPTION	Length	QTY.	ITEM NO.	PART NUMBER	DESCRIPTION	Length	QTY.
1	CC0160	Inner Part of Telescopic Box		1	18	PC0361	Knob - Small Round Plain		1	29	RM0148	Reflector Extrusion Tail	315	2
2	CC0161	Outer Part of Telescopic Box		1	19	PC0362	Energy Reg Extension Shaft		1	30	RM0149	Reflector Extrusion	315	2
3	DC0095	End Cap		1	20	RM0145	Cover Extrusion	80	2	31	RM0150	Lower Side Extrusion	788	2
4	DC0100	Switch Box End		2	21	RM0145	Cover Extrusion	89.5	1	32	RM0150	Lower Side Extrusion	89.5	2
5	DS0047	End Cap Punched		1	22	RM0145	Cover Extrusion	20	1	33	SS2166	HQ Chain Bracket		2
6	EC0239	10A Cord		1	23	RM0146	Side Extrusion	788.5	2	34	SS2168	Ceiling Mount		2
7	EC0397	Ceramic Terminal Block Assy		1	24	RM0146	Side Extrusion	90	1	35	SS2285	Lower Element Retainer		3
8	HC0170	Tubular Element 900W		1	25	RM0146	Side Extrusion	90	1	36	SS2287	Upper Element Guide		2
9	MC0284	Rivet - 73MS 4-2 Truss Head		8	26	RM0147	Centre Extrusion	55	2	37	SS2288	Element Retainer Keeper		2
10	MC0405	Screw M6 x 16 Button Head Socket SS		1	27	RM0147	Centre Extrusion	15	1	38	SS2289	Energy Reg Bracket		1
11	MC0608	Screw - M5 x 12 Ph Torx Zp Trilobe		1	28	RM0147	Centre Extrusion	67	1	39	TC0028	Energy Regulator 16A 240V		1
12	MC0712	Screw - M5 x 8 Button Head Torx SS		2										
13	MC0747	Screw 8g x 1/4 Type B T20 Torx Self Tapping		18										
14	MC0748	Screw 6g x 16 Type AB Pozl Csk SS self Tapping		8										
15	MC0750	Screw - M4 x 10 Long CS T20 torx SS		8										
16	NC0005	Rating Plate		1										
17	PC0060	Cord Clamp - 10A		1										

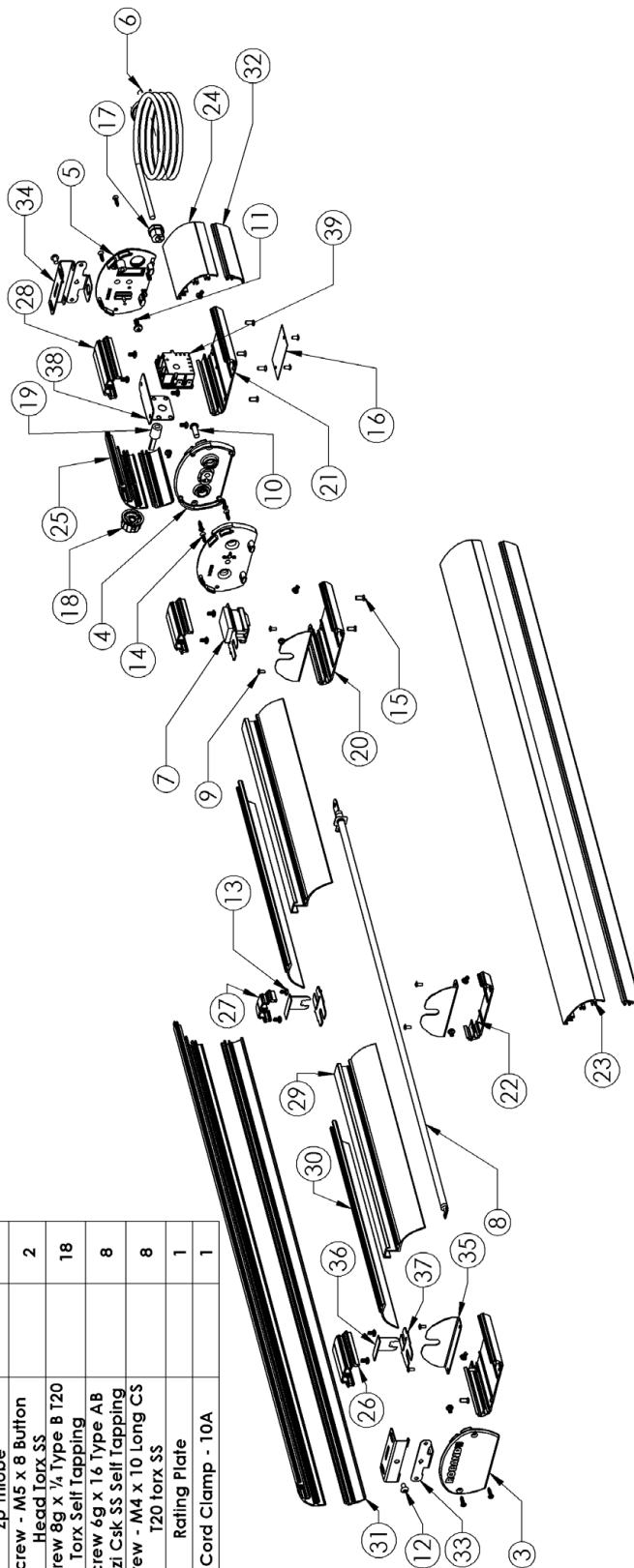

Note: HUE models have the same assembly with the exception of the switch box.

EC DECLARATION OF CONFORMITY

Manufacturer	Roband Australia 1 Inman Rd Cromer NSW, 2099 Australia
Model Type	Extruded Aluminium Infrared Heating Assembly
Description	Heating assemblies utilising metallic infrared heating elements
Date of first CE Marking	12th September 2007
Specific Models	HE, HUE Series

Standards:

This machine is designed in compliance with

- Machinery Directive 2006/42/EC
- Low Voltage Directive 2006/95/EC
- EMC Directive 89/336/EEC including amendments to 93/68/EEC
- WEEE Directive 2002/96/EC (WEEE)
- Restriction of Hazardous Substances in Electrical and Electronic Equipment 2002/95/EC (RoHS)
- EN60335.1 Household and similar Electrical Appliances
- EN60335-2-48 Commercial Electric Toasters and Grillers
- EN60335-2-38 Commercial Electric Griddles & Grills
- EN55014.2: 1997 Electromagnetic compatibility. Requirements for household appliances, electric tools and similar apparatus. Immunity.

Environmental:

This product is designed in order to contribute as little as possible to the quantity and noxious nature of waste and risk of pollution or other environmental contamination.

Packaging materials used in this machine are designed to be recyclable.

Declaration

I hereby declare under our sole responsibility that the product mentioned above to which this declaration relates complies with the above-mentioned standard(s).

Signature of Authorised Person: _____



Date: 12th September 2007

Print Name: Gordon Thorpe

Position: Director of Engineering



WARRANTY

Every care is taken to ensure that no defective equipment leaves our factory and all goods manufactured by us are guaranteed against faulty workmanship and materials for a period of 12 months from the date of purchase. Glass, lamps and Teflon coatings are **not** included in this warranty. Generally, all goods claimed under this warranty must be returned to the factory or an authorised service agent, freight prepaid, for inspection. Any part deemed to be defective will be replaced, however, no claims will be entertained for parts damaged in transport, misused or modified in any way without our approval. For machines that are not considered to be portable (e.g. food bars, rotisseries, large hotplates and some bain maries), on site warranty service will be provided in capital city metropolitan areas only. In all other locations, the customer is responsible for all travelling time/service call costs and payment for this will be required prior to the commencement of the repair. The labour costs to actually repair the fault will be met by this company.

This company reserves the right to reject a claim for warranty if it is not completely satisfied with the circumstances under which it occurred and any costs incurred for false claims or faults due to incorrect usage etc. are the responsibility of the claimant. Under no circumstances shall Roband Australia Pty Ltd or any subsidiary company or Agent be liable for loss of profit or damage to other equipment and property.

Generally, authorised service agents are located in all areas which have authorised distribution dealers. For the name of your nearest authorised service agent please contact:

ROBAND AUSTRALIA PTY LTD

Warranty Number: 1800 268 848 (for Australian residents)
Phone: +61 2 9971 1788 Fax: +61 2 9971 1336
Email: warranty@roband.com.au

All other countries please contact your selling agent.

Please complete the following details and keep this card in a safe place.

NAME: _____
ADDRESS: _____
MODEL No.: _____ SERIAL No.: _____ DATE PURCHASED: _____
NAME OF DEALER: _____

PLEASE RETAIN THIS SECTION FOR YOUR RECORDS

DO NOT POST
ROBAND AUSTRALIA PTY LTD

OTHER LEADING PRODUCTS AVAILABLE:

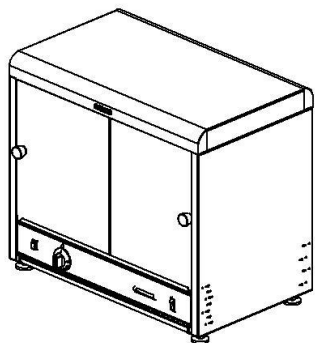

π-PLUS
PIE & FOOD WARMERS

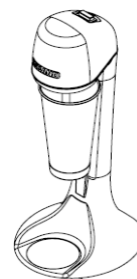

DRINK MIXERS

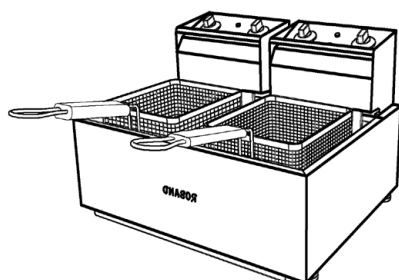

HIGH PERFORMANCE DEEP FRYERS

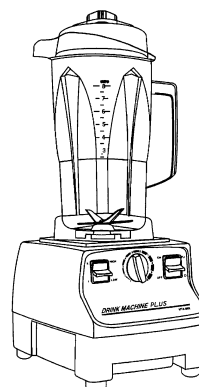

VITAMIX BLENDERS

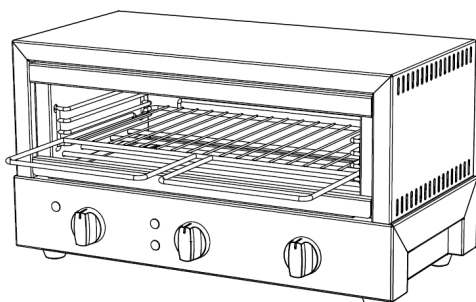

GRILLMAX TOASTERS

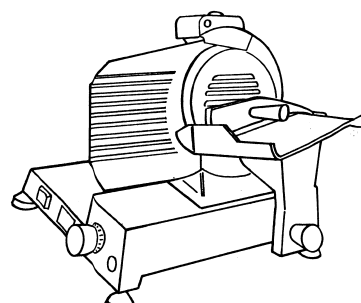

NOAW Slicers

Manufactured/Imported in Australia by:

ROBAND[®]
AUSTRALIA PTY LTD

Authorised Distributor/Agent